



**DelTech Controls, L.L.C.**

**DeVal Flow Controls Private limited**  
(A DIVISION OF DelTech CONTROLS LLC, USA)

**DeITorq Series -21**  
**ACTUATOR**

**INSTALLATION,  
OPERATION AND  
MAINTENANCE MANUAL**

ENGINEERING DATA SHEET  
E.D.S. NO – EDS118  
ISSUE DATE -- 26/02/2007



(Please read the entire instructions carefully before installation or servicing.)

**Guarantee:**

“Our liability, with respect of any defect or failure of the goods supplied or for any loss, injury or damage attributable onward is limited to replacement or repair of the defects which under proper use appear therein and arise solely from faulty materials and workmanship. This guarantee is for a period of 18 calendar months after the original goods were first shipped or within 12 calendar months from the date of installation, whichever is earlier, provided that such defective parts are returned without charge to our factory for examination. No other warranty is either expressed or implied.”

**TABLE OF CONTENT**

Item	Description	Page no.
1.	General	2
2.	Technical Data	2
3.	Installation	2
4.	Operation	2
	1 – Double Acting	
	2 – Spring Return	
		2
5.	Maintenance	
	5.1 – General	2
	5.2 – Disassembly	3
	5.3 – Assembly	4
6.	100% Travel Stop Arrangement	7
7.	Size 045 Actuator	7
8.	Storage	7
9.	Exploded View	8
10.	Parts List	8

**1. General:**

This manual contains the important information regarding the installation, operation and troubleshooting of the 'DelTorq' pneumatic actuators. Please read these instructions carefully before operating the actuator.

**Warning:**

- It is important that the actuator should only be used within the pressure limits indicated in our technical specifications.
- Operating the actuator over pressure limits will damage internal parts as well as cause damage to the housing.
- Operating the actuator over temperature limits will damage internal and external components (disassembly of spring return actuator may become dangerous).
- Operating the actuator in corrosive environments with incorrect protection may damage the internal and external parts.
- Do not disassemble the individual spring cartridges. Disassembly may result in personal injury.
- Isolate all airlines and make sure that actuator air connection is vented before installation or servicing of the actuator.
- Do not remove end caps or disassemble the actuator while the actuator is pressurised.
- Before installing onto a valve, make sure that the rotation of the valve and the actuator are the same and that the position indicator orientation is also correct.
- If the actuator is in a system or used within safety devices or circuits, the customer shall ensure that the national and local safety laws and regulations are observed.

**2. Technical Data:**

**Operating Media:** Dry or lubricated air, non-corrosive and inert gas, or light hydraulic oil.

**Air Supply:** 8 bar (116 PSI) Maximum.

**Temperature:**

Standard: -4 °F to 175°F (-20°C to 80°C)

Viton 'O' Rings: -4 °F to 300°F (-20°C to 150°C)

Sillicon 'O' Rings: -40 °F to 175°F (-40°C to 80°C)

**Lubrication:** Factory lubricated for the life of the actuator under normal conditions.

**Construction:** Suitable for indoor and outdoor use.

**External Travel Stops:** ±5° adjustments on 90° strokes.

**3. Installation:**

1. Ensure that the desired failure mode is correct (Refer to figure no. 1,2 & 3). The 'DelTorq' actuator typically operates counter clockwise to open and clockwise to close, it is possible to change this style of operation. If the spring return actuator is not set up in the configuration desired, follow the disassembly procedure section 5.2. Reverse the orientation of the pistons, and then reassemble following the assembly procedure, section 5.3.
2. Mount the actuator to the valve as per the desired orientation (parallel or perpendicular to the pipeline).
3. Connect a regulated air supply to the NPT fitting on the actuator housing. **Caution: The maximum operating pressure is 116 psi (8 bar).**
4. Adjust the stroke adjustment bolts following assembly section 5.3.4. Stroke adjustment bolts can be adjusted by up to ±5°.

**4. Operation:**

The 'DelTorq' actuators have simple operational characteristics. Port 'A' (facing the ports and reading right to left) is connected to the interior cavity between the pistons directing the airflow into/out of the interior cavity. Port 'B' is connected to the end cap cavities directing airflow into/out of the end cap area.

**1 Double Acting (Figure 1):** Air supplied through port 'A' forces the piston away from each other causing the pinion to rotate counter clockwise (with exhaust air exiting through port 'B'). Air introduced through port 'B' forces the piston towards each other causing the pinion to rotate clockwise (with exhaust air exiting through port 'A').

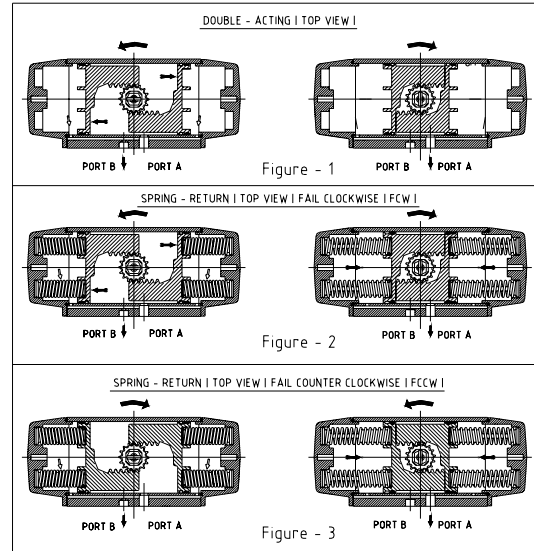

**2 Spring Return:**

**2.1 Fail Clockwise (FCW) (Standard Scope of Supply) (Figure 2):** Air introduced through port 'A' forces the piston away from each other, compressing springs and causing the pinion to rotate counter clockwise (with exhaust air exiting through port 'B'). Upon loss /release of air pressure, springs forces the piston towards center position causing pinion to rotate clockwise (FCW) (with exhaust air exiting through port 'A').

**2.2 Fail Counter Clockwise (FCCW) (Figure 3):** Air introduced through port 'A' forces the piston away from each other, compressing springs and causing the pinion to rotate clockwise (with exhaust air exiting through port 'B'). Upon loss /release of air pressure, springs forces the piston towards center position causing pinion to rotate counter clockwise (FCCW) (with exhaust air exiting through port 'A').

**5 Maintenance:**

**5.1 General:**

'DelTorq' actuator can be supplied with Metric / UNC fasteners. Under normal operating conditions, the actuator requires only periodic observation to ensure proper adjustment. Service kits are available to replace seals and bearings (soft parts). These parts are identified in Figure 24 and listed in Table 4. Table 1 lists kit numbers.

Table 1

Actuator	Service Kit
055	20.SK.055.XX.0
065	20.SK.065.XX.0
075	20.SK.075.XX.0
085	20.SK.085.XX.0
100	20.SK.100.XX.0
115	20.SK.115.XX.0
125	20.SK.125.XX.0
150	20.SK.150.XX.0
175	20.SK.175.XX.0
200	20.SK.200.XX.0

**5.2 Disassembly:**

When disassembly of the actuator is required for maintenance, remove the actuator from the valve. Ensure proper lifting procedures are followed when moving or carrying actuators. **Caution: Do not use M5 VDI/VDE mounting holes for lifting the actuator.**

When disassembling the "DelTorq" actuators, use caution and be certain that the actuator is free from accessories and the air supply is disconnected. When the actuator is a spring-return unit, make sure that the actuator is in the failed position before disassembling.

**1. Removal of Local Position indicator (27) (Figure 4):**

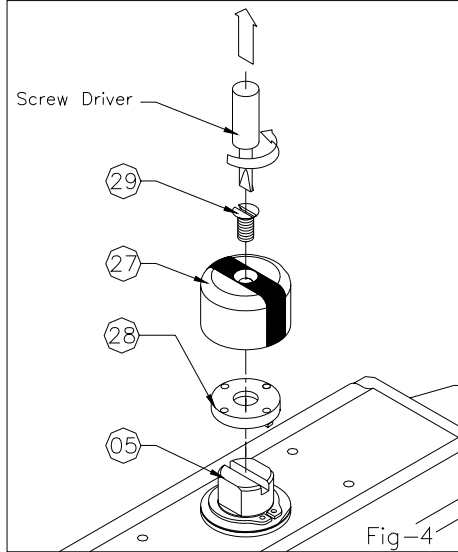

- a) Remove the counter sunk screw (29), if fitted.
- b) Remove the Local position indicator (27) from the pinion (05). It may be necessary to pry gently with a screwdriver.

**2. Removal of Stroke adjustment Bolts (14) (Figure 5):**

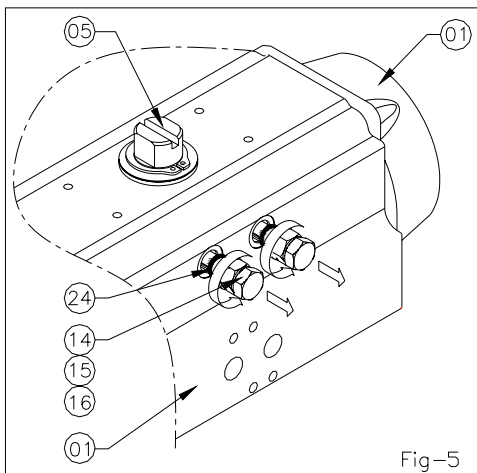

- a) Remove both the Stroke Adjustment Bolts (14) together with nut (16) washer (15) and 'O' Ring (24). Replace the Stroke Adjustment Bolts (14) in case of excessive wear observed on the bolt surface.

**3. End Cap (02, 03) Disassembly (Figure 6):**

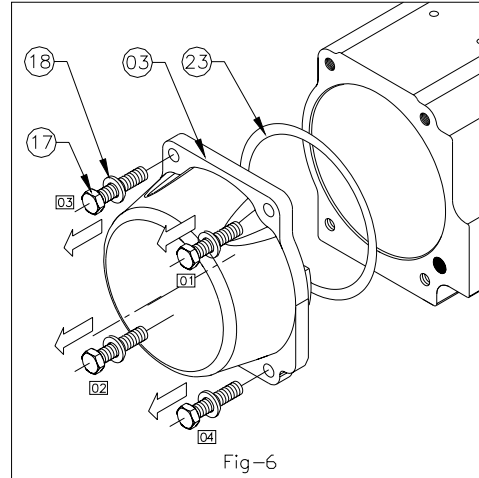

- a) Remove the end cap bolts (17) in the sequence shown in the (figure 6). **Caution: When disassembling a spring return actuator, the end cap (02, 03) should be loose after unscrewing end cap bolts (17) 4-5 turns. If there is still force on the end cap bolt (17), this may indicate a damaged spring cartridge and any further disassembly should be discontinued. Further disassembly of the end caps may result in serious personal injury. Return the actuator to DelTech for further maintenance.**
- b) For spring return actuators, remove spring cartridges (08).
- c) Remove end cap 'O' rings (23) and discard if replacing all soft parts.

**4 Piston (04) Disassembly (Figure 7):**

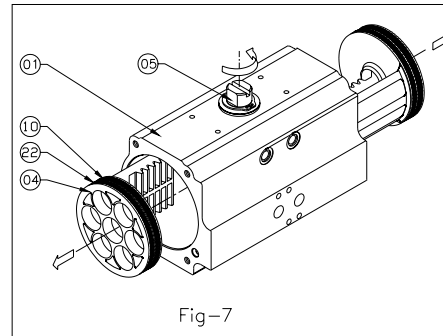

- a) Hold the body (01) in a vice or similar device. Rotate the pinion (05) until the pistons (04) reach the end positions (i.e. the piston rack teeth disengages with pinion teeth). **Caution: Air pressure should not be used to remove the pistons from the body.** Clean and inspect the piston teeth for signs of wear. Replace pistons, if wear seems excessive.
- b) Remove piston 'O' rings (22), piston guide band (10). Discard the 'O' rings and guide band, if replacing the soft parts.

**5. Removal of Pinion (05), Cam (06) and bearings (11, 12) (Figure 8):**

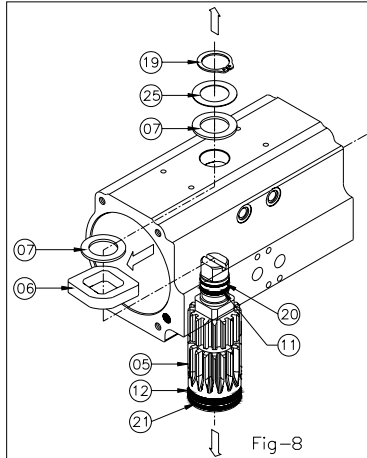

- a) Remove the circlip (19) using a circlip plier.
- b) Remove the shim (25).
- c) Remove the top thrust bush (07).
- d) Apply a downward force to top of the pinion (05) so that the pinion will move out of the center of the body (01) and remove the cam (06), it may be necessary to pry gently to cam with a screwdriver. Observed the cam surface for excessive wear, where the stroke adjustment bolts are resting and the cam ID (Square c/s) replace the cam, if excessive wear is observed.
- e) Apply a downward force to top of the pinion (05) so that the pinion will move completely out of the bottom of the body (01). If the Pinion (05) does not move freely, gently tap with a plastic mallet.
- f) Remove the top and bottom bearings (11, 12) and top and bottom 'O' rings (20, 21). Discard if replacing all soft parts.

**6 Cleaning and inspection:**

When all components are disassembled, those not being replaced should be properly cleaned and inspected for wear prior to re-assembly.

**5.3 Assembly:**

Prior to assembly, ensure that all components are clean and undamaged.

It is recommended to use the lubricants as mentioned in Table 2.

Table 2: Recommended Lubricants	
General Use	CASTROL GREASE - AP3
Low Temperature	MOSIL - SN 64

**1. Pinion (05) Assembly (Figure 09):**

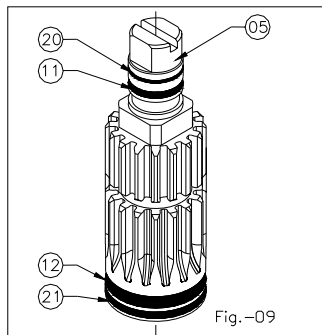

- a) Install the top and bottom bearings (11, 12) and 'O' rings (20, 21) on to the pinion (05).
- b) Apply grease to the pinion bearings (11, 12), shaft 'O' rings (20, 21) using general-purpose grease listed in table 2.

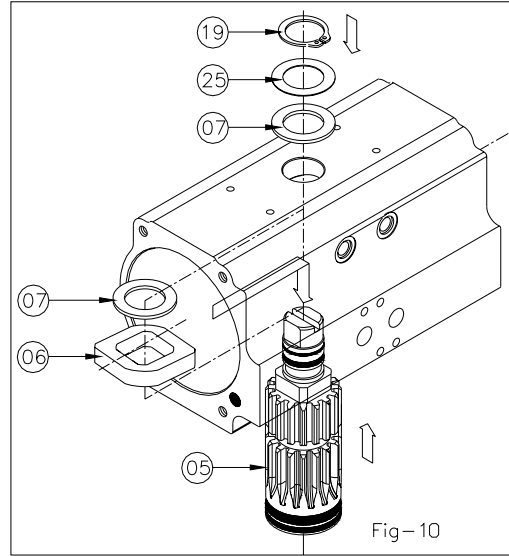

- c) Insert the pinion (05) in to body (01) from the bottom side up to body center.
- d) Insert the cam (06) & bottom thrust bush (07) on the pinion (05).

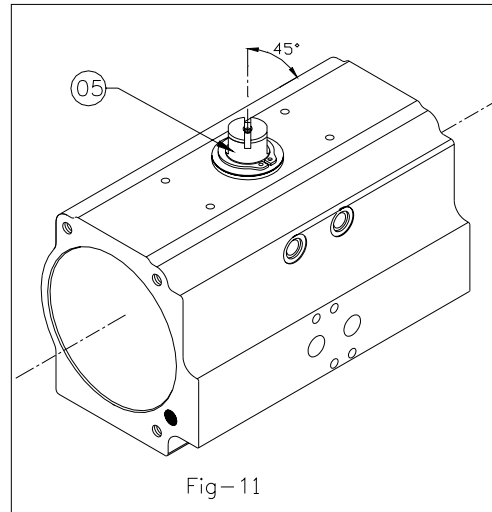

- e) Insert the pinion (05) into the body (01) from the bottom side. Ensure that bottom surface of the pinion should be around 0.5mm inside the body bottom face and the pinion top slot orientation is as shown in figure 11.
- f) Insert the top thrust bush (07) & shim (25) & circlip (19) (using the Circlip Plier) on the pinion (05).

**2. Piston (04) Assembly (Figure 12 & 13):**

- a) Fit piston pad (09), piston guide band (10), and piston o-rings (22) on the pistons (04).
- b) Apply grease to the internal bore of the body (01) & to the piston rack teeth using recommended general - purpose grease listed in table 2.

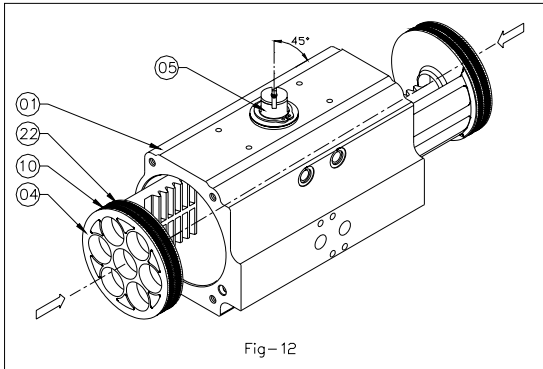

Fig-12

- c) Press the two pistons simultaneously in the body bore until the pinion racks are engaged and rotate the pinion until the stroke is completed. Take care that the pistons are oriented correctly as per the fail position of the actuator (The standard fail action of actuator is fail clockwise). Refer Fig 12 & Fig 13.
- d) To ensure that the piston (04) teeth are evenly engaged, fully compress both the pistons inward and measure the distance from the edge of the body to the piston (04) face on each side, shown as dimension 'A' in figure 13. If a different value is obtained on each side, remove the pistons and repeat from step 2c.

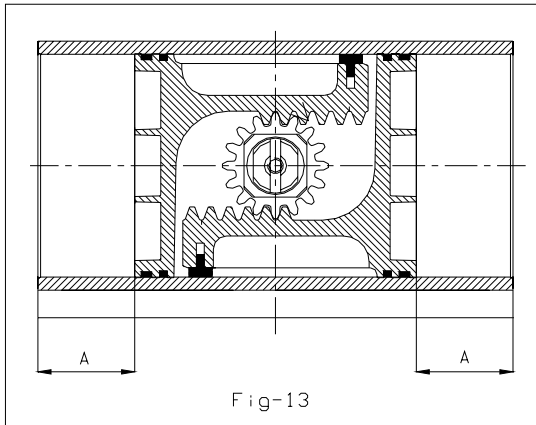

Fig-13

- e) Temporarily install the local position indicator (27) onto the pinion (05) to determine whether the correct stroke is obtained. Ensure that the arrow in the local position indicator (27) will rotate a minimum of 5° beyond the 90° vertical centerline of the actuator body (01) and a minimum of 5° beyond the 0° horizontal centerline of the actuator body as shown in figure 14. If the proper stroke is not obtained, remove the pistons and repeat from step 2c. Once proper stroke is obtained, remove the local position indicator (27).

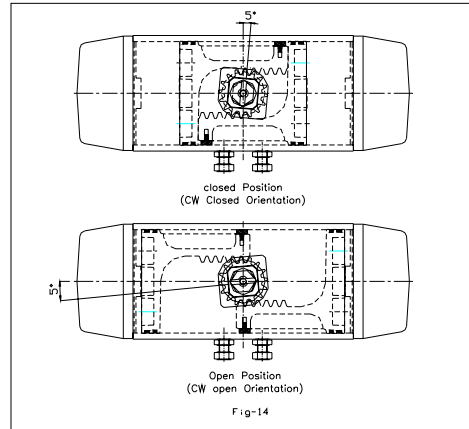

Fig-14

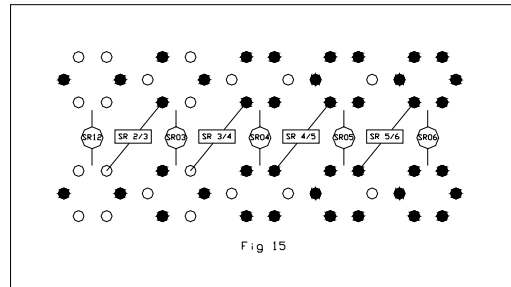

Fig 15

**SPRING RETURN ACTUATORS.**

- For spring return actuator, insert the proper quantity of the spring cartridges (08) according to the pattern shown in Fig 16 (referring to the total number of springs). Insert the spring cartridges (08) as shown in Fig 16.
- Apply grease to the end cap 'O' rings (23). Fit the 'O' rings (23) into the groove in each end cap (02, 03). Fit the Plug Transfer port (13) inside the body (01) on each side. Fit the end caps. Insert all the end cap bolts (17) (Apply grease to the end cap bolts refer table no-3) and hand tighten. Complete tightening by following the sequence indicated in Fig 16.

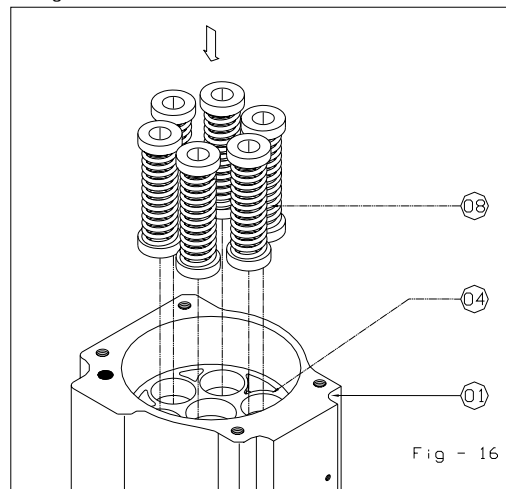

Fig - 16

**DOUBLE ACTING ACTUATORS**

**Table 3 : Recommended Lubricants**

ANTI SIZE GREASE	MOSIL - 2200
------------------	--------------

- Apply grease to (refer table no-2) the end cap 'O' rings (23). Fit the 'O' rings (23) into the groove in each end cap (02, 03). Fit the Plug Transfer port (13) inside the body (01) on each side.
- Fit the end caps (02, 03) onto the body (01), verifying that the 'O' rings (23) remain in the groove. Insert all the end cap bolts (17) (Apply grease to the end cap bolts refer table no.3) and hand tighten. Complete tightening by following the sequence indicated in Fig 17.

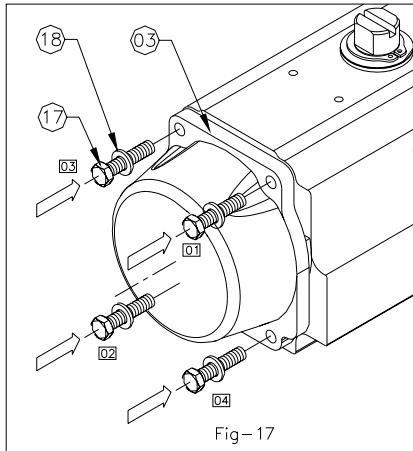

**3. Assembly of Stroke Adjustment Bolts (14): (Figure 18)**

- Insert the nut (16), washer (15) onto the stroke adjustment bolt.
- Insert the "O" Rings (24) in the body (01) "O" Ring groove.
- (Apply grease to the stroke adjustment bolt (14) Refer table No. 3) Screw in the bolts (14) into the body (01).

**4. External Travel Stop Adjustment (Figure 18):**

The stroke adjustment bolt to the right controls the clockwise end of travel, while to the left controls the counter-clockwise end of travel.

- Cycle the actuator to the clockwise end of travel and determine if the pinion top slot is in the proper position (In most of the applications this will be perpendicular to the actuator body i.e. at 90°)
- If the pinion top slot is not in the correct position, turn the right stop adjustment bolt (14) IN to reduce actuator travel, or OUT to increase actuator travel.
- When the correct clockwise position is obtained, hold the adjusting bolt (14) stationary while tightening the nut (16).
- Cycle the actuator to the counter-clockwise end of travel and measure to determine if the pinion top slot is in the proper Position. (In most of the applications, this will be parallel to the actuator body i.e. at 0°).
- If the pinion top slot is not in the correct counter-clockwise position, turn the left stop adjustment bolt (14) to reduce actuator travel, or OUT to increase actuator travel.
- When the correct counter-clockwise position is obtained, hold the adjusting bolt (14) stationary while tightening the nut (16).
- Special machined slot provided on the stroke adjustment bolt to release the pressurized air after extra Opening of the bolts hence to avoid blow out of the stroke adjustment bolts. (As shown in fig. 18a)

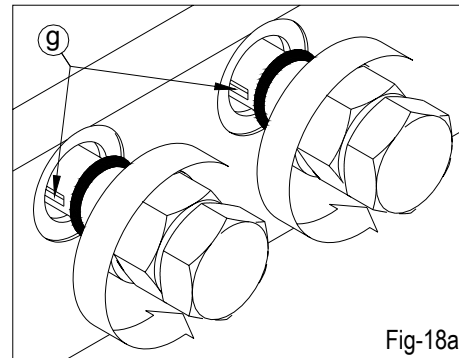
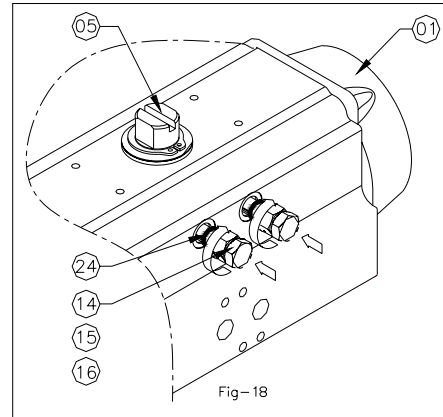

**5. Local Position indicator Assembly (Figure 19):**

- Fit local position indicator (27) assembly on to the pinion (05). Ensure that it indicates the correct Actuator position. Tighten the counter sunk screw (29) to secure the local position indicator

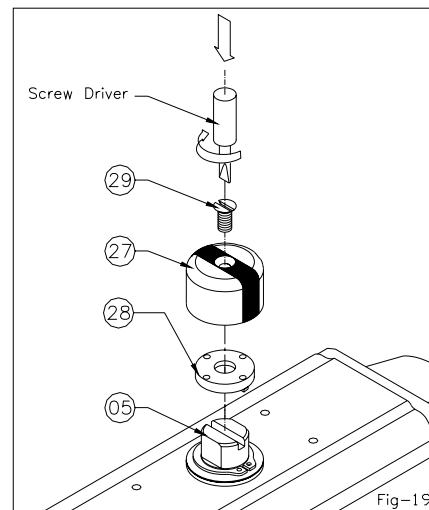

**6. 100% TRAVEL STOP ARRANGEMENT. (FIG No. 20 & 21)  
(OPTIONAL)**

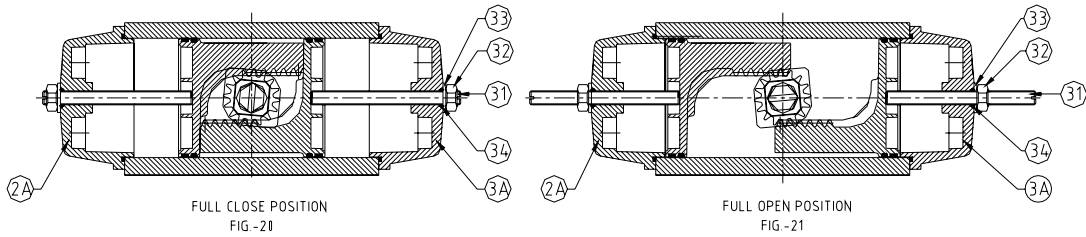

This arrangement is used to restrict opening of the actuator to any position between full close (-5°) to full open (100°) position. This is achieved by rotating the stop bolt (31) in clock wise / counter clock wise direction as per the desired stroke.

**Note:** - 100% travel stop arrangement is possible in only one direction i.e. during opening of the actuator.

**7. SIZE 045 ACTUATOR**

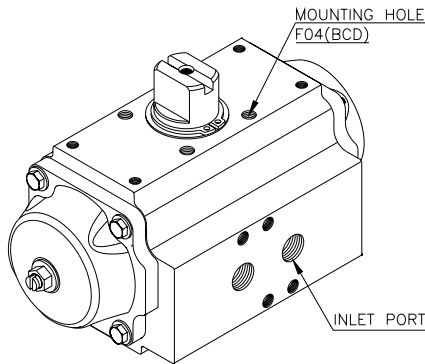

FIG.-22

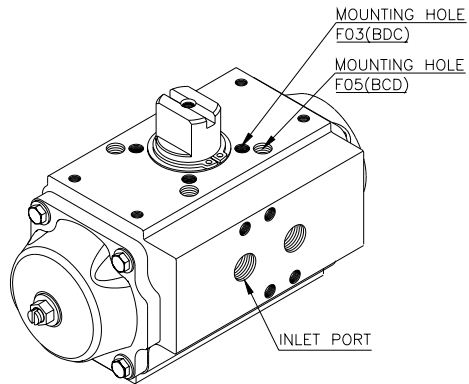

FIG.-23

**7.1** Pinion design permits pinion to be inserted from top or bottom of the actuator to use all three bolts circles (F03, F04 & F05).

**7.2** To use F03 & F05 Bolt Circle, Actuator to be assembled as shown in fig -22

**Note:** - For Double acting actuator air to flow in right inlet port to open the actuator, to close the actuator air to flow in the left inlet port. In spring return actuator air to flow in right inlet port to compress the springs and open the actuator, Springs to close the actuator.

**7.3** To use F04 Bolt Circle, Actuator to be assembled as shown in fig -23

**Note:** - For Double acting actuator air to flow in left inlet port to open the actuator, to close the actuator air to flow in the right inlet port. In spring return actuator air to flow in left inlet port to compress the springs and open the actuator, Springs to close the actuator.

**7.4** External travel stop arrangement given for opening the actuator at 0 to 90° or 0° to 95° position.

**8. Storage:**

All the 'DelTorq' actuators are factory lubricated for one million cycles under normal operating conditions. The ports are plugged to prevent material from entering the actuator during the shipment. If the actuators are not for immediate use, the following precautions must be taken during storage.

- a) Store in a dry environment.
- b) It is recommended that the actuator be stored in its original box.
- c) Do not remove the plastic plugs on the air supply ports.

9. Exploded View: (Figure-24)

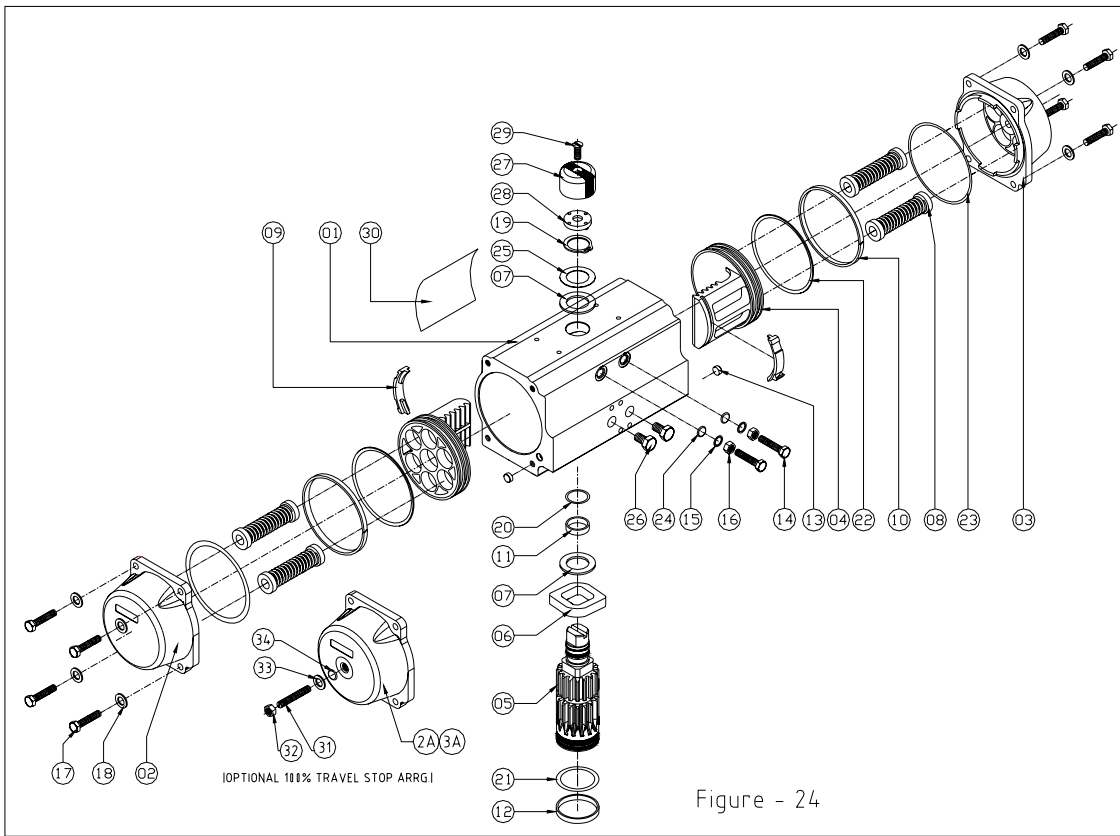

10. Part List:

TABLE - 3

No.	PART DESCRIPTION	MATERIAL SPEC.	QTY	No.	PART DESCRIPTION	MATERIAL SPEC.	QTY
01	BODY	ASTM B221.6063 - T3	01	19	* CIRCLIP	SPRING STEEL	01
02	LEFT END CAP	LM - 24 PDC	01	20	* O-RING	NITRILE RUBBER	01
03	RIGHT END CAP	LM - 24 PDC	01	21	* O-RING	NITRILE RUBBER	01
04	PISTON	LM - 24	02	22	* O-RING	NITRILE RUBBER	02
05	PINION	EN19 + ENP	01	23	* O-RING	NITRILE RUBBER	02
06	CAM	IC4140 + ARCOR	01	24	* O-RING	NITRILE RUBBER	02
07	* PINION TOP / BOTTOM THRUST BUSH	STAYNL TW 371	02	25	* SHIM	SS304	01
08	** SPRING CARTRIDGE ASSEMBLY	--	12 MAX.	26	1/4" PLUGE	PLASTIC	02
09	* PISTON PAD	STAYNL TW 371	02	27	LOCAL POSITION INDICATOR (DOMEI)	ABS PLASTIC	01
10	* PISTON BAND	STAYNL TW 371	02	28	DISC	ABS PLASTIC	01
11	* TOP BUSH	STAYNL TW 371	01	29	COUNTR SUNK SCREW	SS304	01
12	* BOTTOM BUSH	STAYNL TW 371	01	30	ACTUATOR MAIN STICKER	PVC	01
13	* PLUG TRANSFERPORT	NITRILE	02	2A***	LEFT END CAP (100% TRVEL STOP ARRGI)	LM - 24 PDC	01
14	STROKE ADJUSTABLE BOLT	SS304	02	3A***	RIGHT END CAP (100% TRVEL STOP ARRGI)	LM - 24 PDC	01
15	WASHER	SS304	02	31***	STOP BOLT	SS304	02
16	HEX NUT	SS304	02	32***	NUT	SS304	02
17	HEX HEAD SCRW	SS304	08	33***	WASHER	SS304	02
18	M/C WASHER	SS304	08	34***	O' RING	NITRILE RUBBER	02

\* Suggested spare parts for maintenance  
 \*\* Valid for Spring Return Actuator only  
 \*\*\* Optional Only for 100% travel stop Arrangement.



Document Path: server/design server/EDS/EDS055	Rev No: 00	Published On: --
--	------------	------------------